

## iMR-500

Order number:  
1L085X015NXACX-GV01

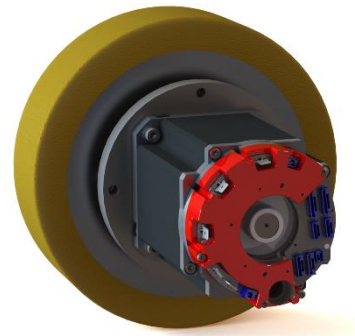

Characteristic	Unit	Value
Motor technology		SPM
Wheel diameter	mm	200
Gearbox type		Planetary helical gears
Gearbox ratio		10:1
Rated voltage	V <sub>DC</sub>	24-58
Peak Current	A <sub>rms</sub>	60
Max torque	Nm	85.5
Max speed	rpm	190
	m/s	2.0
	km/h	7.2
Peak power	kW	0.82
Max Radial Load per wheel	N	5000
Unit weight	kg	8

Specification	Detail
Wheel material	PU-Rad: 85°±3° Shore A
Brake	NA
Feedback	20 bits
Thermal protection	PT 1000
Comm. Interface	EtherCAT, FSoE
Safety Functions	FSoE, STO, SBC, SS1, SOS, SMS, SLS, SLP, SLT, Safe Process Data

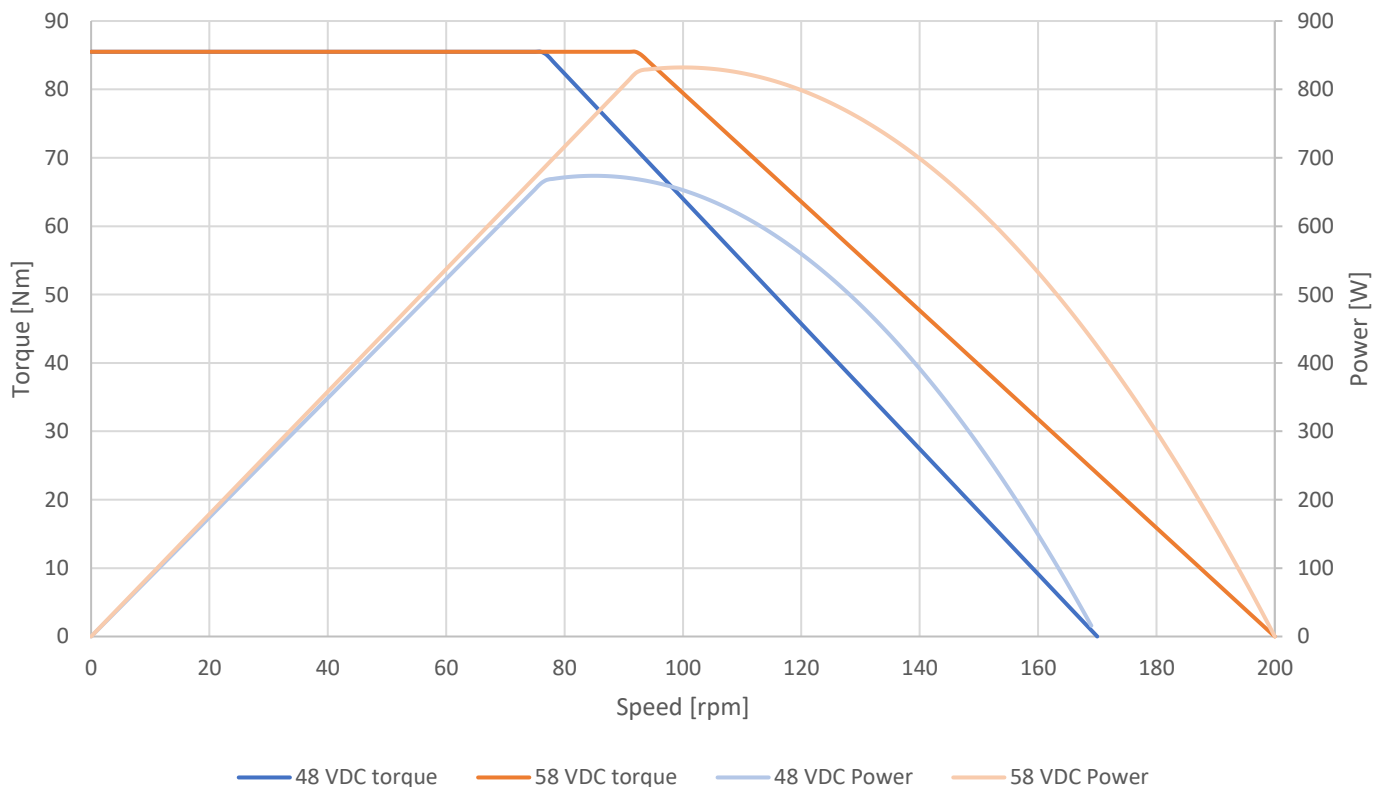

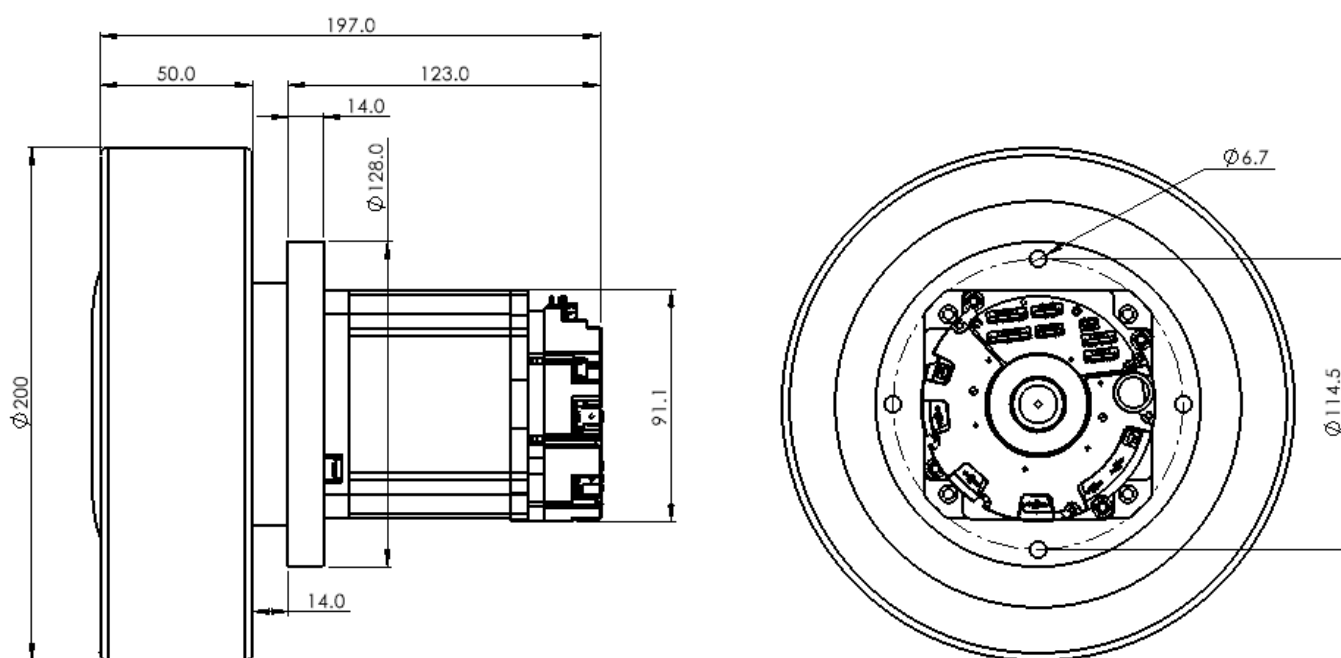

### Connector guide

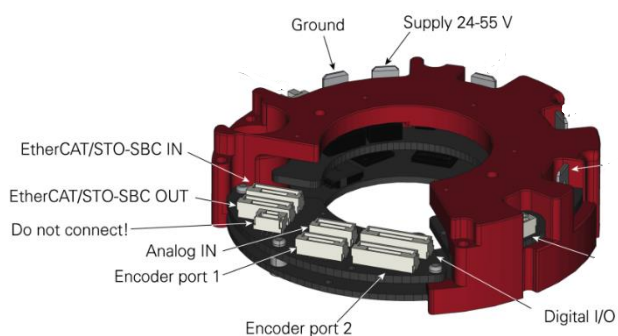

### EtherCAT / STO-SBC IN & OUT

Connector JST GHR-08V-S

Pin	
1	STO-SBC in 1
2	STO-SBC in 2
3	Safety GND
4	RX_N
5	RX_P
6	TX_N
7	TX_P
8	FE

